

# Appendix B

## Functional Scenario

\*abbreviations and acronyms

CN	: Correspondent Node
HA	: Home Agent
MN	: Mobile Node
R	: Router
FL	: Foreign Link
HL	: Home Link
HoA	: Home Address
CoA	: Care-of Address
BCE	: Binding Cash Entry
BLE	: Binding Update List Entry
BU	: Binding Update
BA	: Binding Acknowledgement
DHAAD	: Dynamic Home Agent Address Discovery
HAAD	: Home Agent Address Discovery
MPS	: Mobile Prefix Solicitation
MPA	: Mobile Prefix Advertisement
HoTI	: Home Test Init
HoT	: Home Test
CoTI	: Care-of Test Init
CoT	: Care-of Test
RR	: Return Routability
Co-Reg	: Correspondent Registration
De-Reg	: De-Registration
Re-Reg	: Re-Registration

# <A2B-MN-CN>

## A2B-MNCN-1

### 1. Name of Interoperability Test Scenario

A2B-MNCN-1 Communication between moving MN and CN using bidirectional RO and DHAAD.

### 2. Purpose & Outline

MN, booted up on Foreign link, moves to another Foreign link or Home link with following condition. MN communicates with CN which does not move.

- CN performs Route Optimization
- MN performs Route Optimization
- MN performs DHAAD (single HA)

### 3. Test Setup

#### 3.1 Topology

The topology to execute this scenario is shown below.

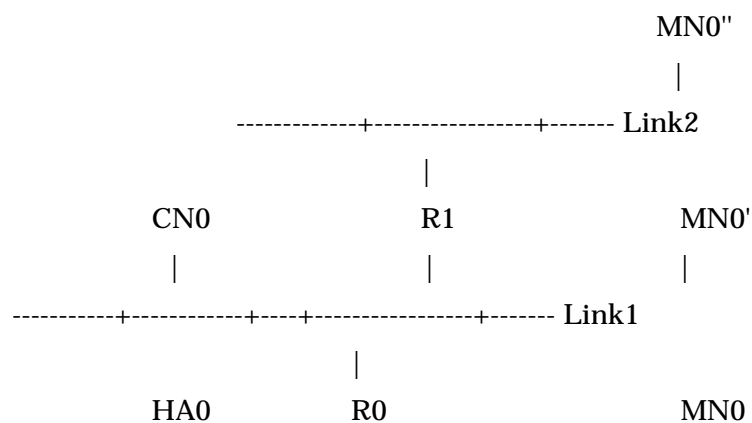



(home link)

<<Link Information>>

-Link0

3ffe:501:ffff:100::/64

home link

-Link1

3ffe:501:ffff:101::/64

foreign link

-Link2

3ffe:501:ffff:102::/64

foreign link

<<Node Information>>

-HA0

3ffe:501:ffff:100::200

-MN0(Link0)

3ffe:501:ffff:100::(Interface id) or 3ffe:501:ffff:100::300

Home address

-MN0'(Link1)

3ffe:501:ffff:101::(Interface id)

Care-of address

-MN0"(Link2)

3ffe:501:ffff:102::(Interface id)

Care-of address

-R0(Link0)

3ffe:501:fff:100::1

-R0(Link1)

3ffe:501:fff:101::1

-R1(Link1)

3ffe:501:fff:101::2

-R1(Link2)

3ffe:501:fff:102::2

-CN0(Link1)

3ffe:501:fff:101::100

### 3.2 Test Initial conditions

In order to execute this scenario, the following Initial condition should be satisfied.

(a) CN

- Does not have Binding Cache Entry for MN0.

(b) HA

- Does not have Binding Cache Entry for MN0.
- Use IPsec as described in Appendix.

(c) MN

- Set HoA(3ffe:501:fff:100::(Interface id) or 3ffe:501:fff:100::300).
- Configure to perform DHAAD to get HA address.
- Configure to run Stateless address autoconfiguration to set CoA.
- Use IPsec as described in Appendix.

## 4. Test Procedure

### 4.1 Procedure

The procedure to execute this scenario is stated as follows.

<<Procedure>>

<No>1 >> 1-4-1-10

<No>1-1

<Procedure> Boot up MN0 on Link1(MN0').

<No>1-2

<Procedure> Ping (5 times). CN0->MN0'

<No>2 >> 1-4-2-6

<No>2-1

<Procedure> Repeat ping CN0->MN0' until 2-3  
e.g.,)ping -t (windows)

<No>2-2

<Procedure> MN0' stays on the same link(Link1) and wait for 450(sec).  
(Confirm that MN0' performs re-registration to refresh the lifetime)  
CN: max 420(sec)  
HA: If configurable, CN+30(sec)

<No>2-3

<Procedure> Stop ping

<No>3 >> 1-4-3-5

<No>3-1

<Procedure> Move MN0' from Link1(MN0') to Link2(MN0'')  
(Move to next link before BCE expiration)

<No>3-2

<Procedure> Ping (5 times). CN0->MN0''

<No>4 >> 1-4-3-8

<No>4-1

<Procedure> Move MN0" from Link2(MN0") to Link0[home link](MN0)  
(Move to next link before BCE expiration)

<No>4-2

<Procedure> Ping (5 times). CN0->MN0

<No>5 >> 1-4-3-2

<No>5-1

<Procedure> Move MN0 From Link0[home link] to Link1(MN0')  
(Move to next link before BCE expiration)

<No>5-2

<Procedure> Ping (5 times). CN0->MN0'

<No>6 >> 1-4-3-4

<No>6-1

<Procedure> Move MN0' from Link1(MN0') to Link2(MN0'')  
(Move to next link before BCE expiration)

<No>6-2

<Procedure> Ping (5 times). MN0''->CN0

<No>7 >> 1-4-3-7

<No>7-1

<Procedure> Move MN0" from Link2(MN0'') to Link0[home link](MN0)  
(Move to next link before BCE expiration)

<No>7-2

<Procedure> Ping (5 times). MN0->CN0

<No>8 >> 1-4-3-1

<No>8-1

<Procedure> Move MN0 From Link0[home link] to Link1(MN0')  
(Move to next link before BCE expiration)

<No>8-2

<Procedure> Ping (5 times). MN0'->CN0

## 1-4-1-10

### 1. Name of Basic Scenario

1-4-1-10 Operation check from MN booting-up to the confirmation of communication between MN and CN.

(Communication between MN and CN, Route Optimization, booting-up)

### 2. Purpose & Outline

To check the consecutive operation, starting from MN booting-up to the confirmation of communication between MN and CN.

Test requirements for this scenario are listed as follows.

CN Route Optimization	: ON
MN Route Optimization	: ON
State of the MN	: Booting-up
Location of the MN	
Initial Network	: Foreign
Last Network	: Foreign
HA Address of the MN	: DHAAD
Direction of Communication	: CN->MN
IPsec	: ON (transport mode, tunnel mode)
IKE	: OFF

### 3. Resource Requirement

Requirements for Mobile IPv6 Node are listed as follows.

<<Requirement and Reference>>

<Device> CN

<Requirement> Not in particular

<Reference>(Responding to Implementation Guideline)

- Payload Packets
  - 9.3.1 item No.3 - 9.3.1 item No.4
  - 9.3.1 item No.8
  - 9.3.2 item No.15 - 9.3.2 item No.16
- Route Optimization
  - 9.4.1 item No.1 - 9.4.4 item No.8
- CN Registration
  - 9.5.1 item No.1 - 9.5.1 item No.25,
  - 9.5.2 item No.26 - 9.5.2 item No.31,
  - 9.5.4 item No.35 - 9.5.4 item No.48

<Device> HA

<Requirement> Not in particular

<Reference>(Responding to Implementation Guideline)

- Dynamic Home Agent Address Discovery
  - 10.5 item No.11 - 10.5 item No.13
- Registration
  - 10.3.1 item No.1 - 10.3.1 item No.39
- Payload Packets
  - 10.4.1 item No.1 - 10.4.1 item No.30
  - 10.4.5 item No.40 - 10.4.5 item No.43
- Route Optimization
  - 10.4.6 item No.44 - 10.4.6 item No.47

<Device> MN

<Requirement>- being equipped with the function of stateful or stateless address autoconfiguration and under the foreign link, Care-of address should be assigned.

<Reference>(Responding to Implementation Guideline)

- Dynamic Home Agent Address Discovery
  - 11.4.1 item No.1 - 11.4.1 item No.2
- Registration
  - 11.7.1 item No.1 - item No.25,
  - 11.7.3 item No.50 - item No.61,
  - 4.2 item 11 - item 19,

- 4.3 item 20 - item 22
- Payload Packets
  - 11.3 item No.34 - 11.3 item No.36
- Route Optimization
  - 11.3.1 item No.9 - item No.13
  - 11.6.1 item No.1 - item No.9
  - 11.6.2 item No.10 - item No.25
  - 11.6.3 item No.26 - item No.28
- CN Registration
  - 11.7.1 item No.1 - item No.25,
  - 11.7.3 item No.50 - 11.7.3 item No.61

#### 4. Test Setup

##### 4.1 Topology

The topology to execute this scenario is shown below.

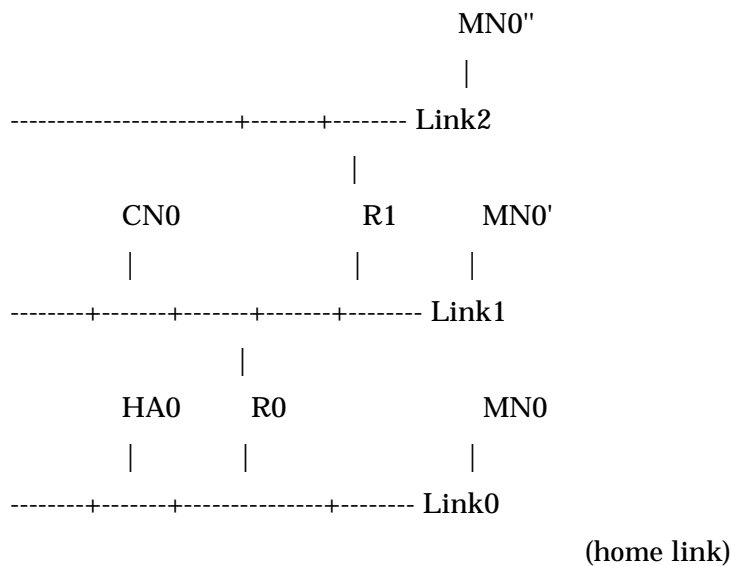

<<Link Information>>

-Link0

3ffe:501:fff:100::/64

home link

-Link1

3ffe:501:fff:101::/64

Foreign link

-Link2

3ffe:501:fff:102::/64

Foreign link

<<Node Information>>

-HA0(Link0)

3ffe:501:fff:100::200

-MN0(Link0)

3ffe:501:fff:100::(Interface id) or 3ffe:501:fff:100::300

Home address

-MN0'(Link1)

3ffe:501:fff:101::(Interface id)

Care-of address

-MN0"(Link2)

3ffe:501:fff:102::(Interface id)

Care-of address

-R0(Link0)

3ffe:501:fff:100::1

-R0(Link1)

3ffe:501:fff:101::1

-R1(Link1)

3ffe:501:fff:101::2

-R1(Link2)

3ffe:501:ffff:102::2

-CN0(Link1)

3ffe:501:ffff:101::100

#### 4.2 Test Initial conditions

In order to execute this scenario, the following Initial conditions should be satisfied.

(1)CN0

- Does not have Binding Cache Entry for MN0.

(2)HA0

- Does not have Binding Cache Entry for MN0.
- The following set-up be configured.
  - o IPsec : (ref. Appendix B)

(3)MN0

- Does not have Binding List Entry for HA0.
- Does not have Binding List Entry for CN0.
- The following set-up be configured.
  - o HoA(Home Address) : (manual configuration or stateless address autoconfiguration)
  - o HA Address : DHAAD
  - o CoA(Care-of Address) : (stateful or stateless address autoconfiguration)
  - o IPsec : (ref. Appendix B)

### 5. Test Procedure

#### 5.1 Procedure

The procedure to execute this scenario is stated as follows.

<<Procedure>>

<No>1

<Procedure> Boot up MN0 under Link1

<No>2

<Procedure> Continuously running ping6 command to HoA of MN0 under CN0  
(ref. 6.Judgement)

## 5.2 Related Mobile IPv6 sequences

The following is expected Mobile IPv6 sequence under the actual execution of this scenario.

MN0	HA0	CN0
MN0'		Booting-up(Link1)
----->		HAAD Req
<-----		HAAD Rep
----->		BU
<-----		BA
<=====	-----	Echo Request
=====	----->	HoTI
----->		CoTI
<-----		CoT
<=====	-----	HoT
----->		BU
<-----		BA(opt)
=====	----->	Echo Reply
<-----		Echo Request
----->		Echo Reply

## 6. Judgement

- (1) Both Echo Request/Echo Reply should be received and sent between MN0 and CN0.
- (2) The route between MN0 and CN0 should be optimized.

### Check-up procedure

e.g.)

- Execute "tracert6" to HoA of MN0 under CN0  
Route display procedure : CN0 -> CoA of MN0 -> HoA of MN0
- MN0's Binding Cache entry should be created in HA0.
- MN0's Binding Cache entry should be created in CN0.
- HA0's Binding Update List entry should be created in MN0.
- CN0's Binding Update List entry should be created in MN0.
- Packet of MN0 and CN0 after Route Optimization (use tcpdump etc)  
Type2 Routing Header should be attached to Echo Request of CN0 -> MN0  
Home Address Option should be attached to Echo Reply of MN0 -> CN0

## 1-4-2-6

### 1. Name of Basic Scenario

1-4-2-6 Operation check the confirmation of communication between MN and CN when MN stays in foreign link.

(Communication between MN and CN, Route Optimization, stationary)

### 2. Purpose & Outline

To check the consecutive operation, starting from MN stays in foreign link to the confirmation of communication between MN and CN.

Test requirements for this scenario are listed as follows.

CN Route Optimization	: ON
MN Route Optimization	: ON
State of the MN	: Stationary
Location of the MN	
Initial Network	: Foreign
Last Network	: Foreign
HA Address of the MN	: N/A
Direction of Communication	: Any direction
IPsec	: ON (transport mode, tunnel mode)
IKE	: OFF

### 3. Resource Requirement

Requirements for Mobile IPv6 Node are listed as follows.

<<Requirement and Reference>>

<Device> CN

<Requirement> Not in particular

<Reference>(Responding to Implementation Guideline)

- Payload Packets
  - 9.3.1 item No.3 - 9.3.1 item No.4
  - 9.3.1 item No.8
  - 9.3.2 item No.15 - 9.3.2 item No.16
- Route Optimization
  - 9.4.1 item No.1 - 9.4.4 item No.8
- CN Registration
  - 9.5.1 item No.1 - 9.5.1 item No.25,
  - 9.5.2 item No.26 - 9.5.2 item No.31,
  - 9.5.4 item No.35 - 9.5.4 item No.48

<Device> HA

<Requirement> Not in particular

<Reference>(Responding to Implementation Guideline)

- Registration
  - 10.3.1 item No.1 - 10.3.1 item No.39
- Payload Packets
  - 10.4.1 item No.1 - 10.4.1 item No.30
  - 10.4.5 item No.40 - 10.4.5 item No.43
- Route Optimization
  - 10.4.6 item No.44 - 10.4.6 item No.47

<Device> MN

<Requirement>- being equipped with the function of stateful or stateless address autoconfiguration and under the foreign link, Care-of address should be assigned.

<Reference>(Responding to Implementation Guideline)

- Registration
  - 11.7.1 item No.1 - item No.25,
  - 11.7.3 item No.50 - item No.61,
  - 4.2 item 11 - item 19,
  - 4.3 item 20 - item 22
- Payload Packets
  - 11.3 item No.34 - 11.3 item No.36
- Route Optimization

- 11.3.1 item No.9 - item No.13
- 11.6.1 item No.1 - item No.9
- 11.6.2 item No.10 - item No.25
- 11.6.3 item No.26 - item No.28
- CN Registration
  - 11.7.1 item No.1 - item No.25,
  - 11.7.3 item No.50 - 11.7.3 item No.61

#### 4. Test Setup

##### 4.1 Topology

The topology to execute this scenario is shown below.

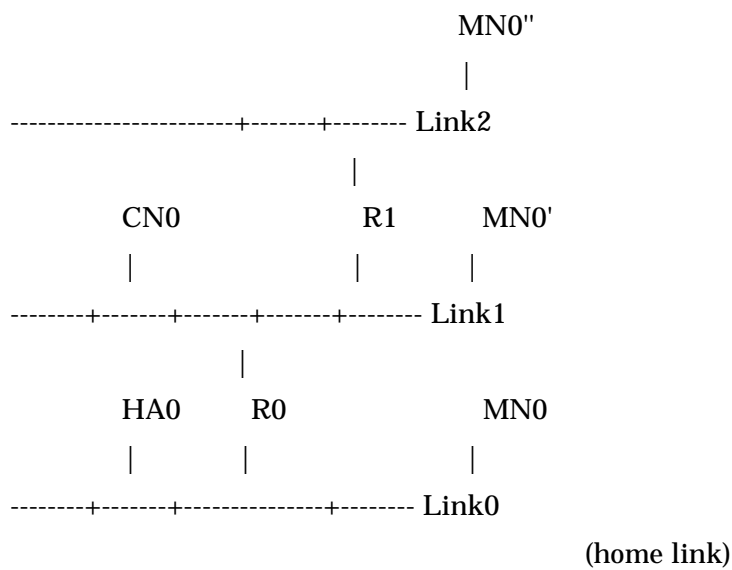

<<Link Information>>

-Link0

3ffe:501:ffff:100::/64

home link

-Link1

3ffe:501:ffff:101::/64

Foreign link

-Link2

3ffe:501:fff:102::/64

Foreign link

<<Node Information>>

-HA0(Link0)

3ffe:501:fff:100::200

-MN0(Link0)

3ffe:501:fff:100::(Interface id) or 3ffe:501:fff:100::300

Home address

-MN0'(Link1)

3ffe:501:fff:101::(Interface id)

Care-of address

-MN0"(Link2)

3ffe:501:fff:102::(Interface id)

Care-of address

-R0(Link0)

3ffe:501:fff:100::1

-R0(Link1)

3ffe:501:fff:101::1

-R1(Link1)

3ffe:501:fff:101::2

-R1(Link2)

3ffe:501:fff:102::2

-CN0(Link1)

3ffe:501:fff:101::100

## 4.2 Test Initial conditions

In order to execute this scenario, the following Initial conditions should be satisfied.

### (1)CN0

- Have Binding Cache Entry for MN0.

### (2)HA0

- Have Binding Cache Entry for MN0.
- The following set-up be configured.
  - o IPsec : (ref. Appendix B)

### (3)MN0

- Have Binding List Entry for HA0.
- Have Binding List Entry for CN0.
- The following set-up be configured.
  - o HoA(Home Address) : (manual configuration or stateless address autoconfiguration)
  - o HA Address : N/A
  - o CoA(Care-of Address) : (stateful or stateless address autoconfiguration)
  - o IPsec : (ref. Appendix B)

## 5. Test Procedure

### 5.1 Procedure

The procedure to execute this scenario is stated as follows.

<<Procedure>>

<No>1

<Procedure> Continuously running ping6 command to HoA of MN0 under CN0 until <No>3

<No>2

<Procedure> MN0 stays on the same link and wait for home re-registration.

(Confirm that MN performs re-registration to refresh the lifetime)

CN(MN): max 420(sec)

HA: If configurable, CN(MN)+30(sec)

<No>3

<Procedure> Stop running ping6

(ref. 6.Judgement)

## 5.2 Related Mobile IPv6 sequences

The following is expected Mobile IPv6 sequence under the actual execution of this scenario.

MN0	HA0	CN0
<=====	-----	Echo Request (continue until reaching at the end.)
=====	----->	Echo Reply
		Stationary (until the re-registration)
----->		BU
<-----		BA
<=====	-----	Echo Request
=====	----->	HoTI
----->		CoTI
<-----		CoT
<=====	-----	HoT
----->		BU
<-----		BA(opt)
=====	----->	Echo Reply
<-----		Echo Request
----->		Echo Reply

## 6. Judgement

(1) Both Echo Request/Echo Reply should be received and sent between MN0 and CN0.

(2) The route between MN0 and CN0 should be optimized.

### Check-up procedure

e.g.)

- Execute "tracert6" to HoA of MN0 under CN0  
Route display procedure : CN0 -> CoA of MN0 -> HoA of MN0
- MN0's Binding Cache entry should be created in HA0.
- MN0's Binding Cache entry should be created in CN0.
- HA0's Binding Update List entry should be created in MN0.
- CN0's Binding Update List entry should be created in MN0.
- Packet of MN0 and CN0 after Route Optimization (use tcpdump etc)  
Type2 Routing Header should be attached to Echo Request of CN0 -> MN0  
Home Address Option should be attached to Echo Reply of MN0 -> CN0

### 1-4-3-1

#### 1. Name of Basic Scenario

1-4-3-1 Operation check starting from MN's home link to foreign link moving to the confirmation of communication between MN and CN.

(Communication between MN and CN, Route Optimization, moving)

#### 2. Purpose & Outline

To check the consecutive operation, starting from MN's home link to foreign link moving to the confirmation of communication between MN and CN.'

Test requirements for this scenario are listed as follows.

CN Route Optimization	: ON
MN Route Optimization	: ON
State of the MN	: Moving
Location of the MN	
Initial Network	: Home
Last Network	: Foreign
HA Address of the MN	: N/A
Direction of Communication	: MN->CN
IPsec	: ON (transport mode, tunnel mode)
IKE	: OFF

#### 3. Resource Requirement

Requirements for Mobile IPv6 Node are listed as follows.

<<Requirement and Reference>>

<Device>      CN

<Requirement> Not in particular

<Reference>(Responding to Implementation Guideline)

- Payload Packets
  - 9.3.1 item No.3 - 9.3.1 item No.4
  - 9.3.1 item No.8
  - 9.3.2 item No.15 - 9.3.2 item No.16
- Route Optimization
  - 9.4.1 item No.1 - 9.4.4 item No.8
- CN Registration
  - 9.5.1 item No.1 - 9.5.1 item No.25,
  - 9.5.2 item No.26 - 9.5.2 item No.31,
  - 9.5.4 item No.35 - 9.5.4 item No.48

<Device> HA

<Requirement> Not in particular

<Reference>(Responding to Implementation Guideline)

- Registration
  - 10.3.1 item No.1 - 10.3.1 item No.39
- Payload Packets
  - 10.4.1 item No.1 - 10.4.1 item No.30
  - 10.4.5 item No.40 - 10.4.5 item No.43
- Route Optimization
  - 10.4.6 item No.44 - 10.4.6 item No.47

<Device> MN

<Requirement>- being equipped with the function of stateful or stateless address autoconfiguration and under the foreign link, Care-of address should be assigned.

<Reference>(Responding to Implementation Guideline)

- Registration
  - 11.7.1 item No.1 - item No.25,
  - 11.7.3 item No.50 - item No.61,
  - 4.2 item 11 - item 19,
  - 4.3 item 20 - item 22
- Payload Packets
  - 11.3 item No.34 - 11.3 item No.36

- Route Optimization

11.3.1 item No.9 - item No.13

11.6.1 item No.1 - item No.9

11.6.2 item No.10 - item No.25

11.6.3 item No.26 - item No.28

- CN Registration

11.7.1 item No.1 - item No.25,

11.7.3 item No.50 - 11.7.3 item No.61

#### 4. Test Setup

##### 4.1 Topology

The topology to execute this scenario is shown below.

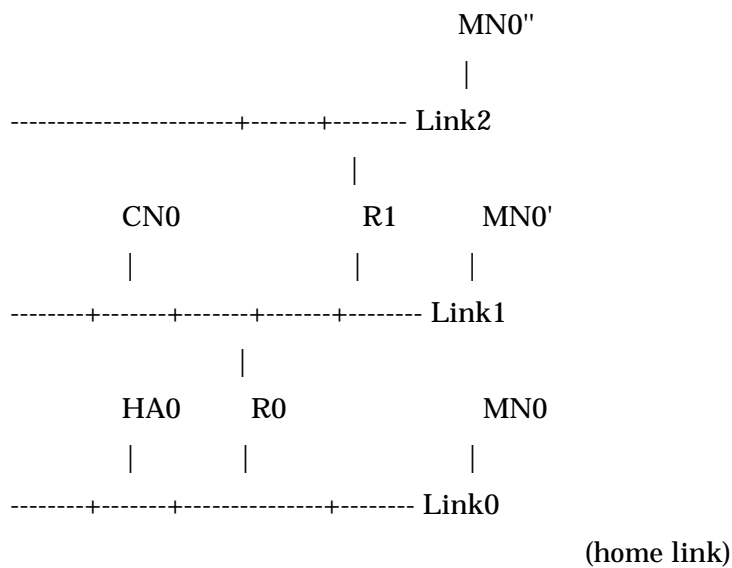

<<Link Information>>

-Link0

3ffe:501:fff:100::/64

home link

-Link1

3ffe:501:fff:101::/64

Foreign link

-Link2

3ffe:501:ffff:102::/64

Foreign link

<<Node Information>>

-HA0(Link0)

3ffe:501:ffff:100::200

-MN0(Link0)

3ffe:501:ffff:100::(Interface id) or 3ffe:501:ffff:100::300

Home address

-MN0'(Link1)

3ffe:501:ffff:101::(Interface id)

Care-of address

-MN0"(Link2)

3ffe:501:ffff:102::(Interface id)

Care-of address

-R0(Link0)

3ffe:501:ffff:100::1

-R0(Link1)

3ffe:501:ffff:101::1

-R1(Link1)

3ffe:501:ffff:101::2

-R1(Link2)

3ffe:501:ffff:102::2

-CN0(Link1)

3ffe:501:ffff:101::100

## 4.2 Test Initial conditions

In order to execute this scenario, the following Initial conditions should be satisfied.

### (1)CN0

- Have Binding Cache Entry for MN0.

### (2)HA0

- Have Binding Cache Entry for MN0.
- The following set-up be configured.
  - o IPsec : (ref. Appendix B)

### (3)MN0

- Have Binding List Entry for HA0.
- Have Binding List Entry for CN0.
- The following set-up be configured.
  - o HoA(Home Address) : (manual configuration or stateless address autoconfiguration)
  - o HA Address : N/A
  - o CoA(Care-of Address) : (stateful or stateless address autoconfiguration)
  - o IPsec : (ref. Appendix B)

## 5. Test Procedure

### 5.1 Procedure

The procedure to execute this scenario is stated as follows.

<<Procedure>>

<No>1

<Procedure> Move MN0 from Link0 to Link1

(Move to next link before binding cache entry expiration)

<No>2

<Procedure> Continuously running ping6 command to CN0 under MN0

(ref. 6.Judgement)

## 5.2 Related Mobile IPv6 sequences

The following is expected Mobile IPv6 sequence under the actual execution of this scenario.

MN0	HA0	CN0
MN0'		Moving(Link0 -> Link1)
----->		BU
<-----		BA
=====	----->	HoTI
----->		CoTI
<-----		CoT
<=====	-----	HoT
----->		BU
<-----		BA(opt)
=====	----->	Echo Request
<=====	-----	Echo Reply

## 6. Judgement

- (1)Both Echo Request/Echo Reply should be received and sent between MN0 and CN0.
- (2)The route between MN0 and CN0 should be optimized.

Check-up procedure

e.g.)

- Execute "tracert6" to HoA of MN0 under CN0

Route display procedure : CN0 -> CoA of MN0 -> HoA of MN0

- MN0's Binding Cache entry should be created in HA0.

- MN0's Binding Cache entry should be created in CN0.

- HA0's Binding Update List entry should be created in MN0.

- CN0's Binding Update List entry should be created in MN0.

- Packet of MN0 and CN0 after Route Optimization (use tcpdump etc)

Type2 Routing Haeder should be attached to Echo Request of CN0 ->MN0

Home Address Option should be attached to Echo Reply of MN0 -> CN0

## 1-4-3-2

### 1. Name of Basic Scenario

1-4-3-2 Operation check starting from MN's home link to foreign link moving to the confirmation of communication between MN and CN.

(Communication between MN and CN, Route Optimization, moving)

### 2. Purpose & Outline

To check the consecutive operation, starting from MN's home link to foreign link moving to the confirmation of communication between MN and CN.

Test requirements for this scenario are listed as follows.

CN Route Optimization	: ON
MN Route Optimization	: ON
State of the MN	: Moving
Location of the MN	
Initial Network	: Home
Last Network	: Foreign
HA Address of the MN	: N/A
Direction of Communication	: CN->MN
IPsec	: ON (transport mode, tunnel mode)
IKE	: OFF

### 3. Resource Requirement

Requirements for Mobile IPv6 Node are listed as follows.

<<Requirement and Reference>>

<Device>      CN

<Requirement> Not in particular

<Reference>(Responding to Implementation Guideline)

- Payload Packets
  - 9.3.1 item No.3 - 9.3.1 item No.4
  - 9.3.1 item No.8
  - 9.3.2 item No.15 - 9.3.2 item No.16
- Route Optimization
  - 9.4.1 item No.1 - 9.4.4 item No.8
- CN Registration
  - 9.5.1 item No.1 - 9.5.1 item No.25,
  - 9.5.2 item No.26 - 9.5.2 item No.31,
  - 9.5.4 item No.35 - 9.5.4 item No.48

<Device> HA

<Requirement> Not in particular

<Reference>(Responding to Implementation Guideline)

- Registration
  - 10.3.1 item No.1 - 10.3.1 item No.39
- Payload Packets
  - 10.4.1 item No.1 - 10.4.1 item No.30
  - 10.4.5 item No.40 - 10.4.5 item No.43
- Route Optimization
  - 10.4.6 item No.44 - 10.4.6 item No.47

<Device> MN

<Requirement>- being equipped with the function of stateful or stateless address autoconfiguration and under the foreign link, Care-of address should be assigned.

<Reference>(Responding to Implementation Guideline)

- Registration
  - 11.7.1 item No.1 - item No.25,
  - 11.7.3 item No.50 - item No.61,
  - 4.2 item 11 - item 19,
  - 4.3 item 20 - item 22
- Payload Packets
  - 11.3 item No.34 - 11.3 item No.36

- Route Optimization

11.3.1 item No.9 - item No.13

11.6.1 item No.1 - item No.9

11.6.2 item No.10 - item No.25

11.6.3 item No.26 - item No.28

- CN Registration

11.7.1 item No.1 - item No.25,

11.7.3 item No.50 - 11.7.3 item No.61

#### 4. Test Setup

##### 4.1 Topology

The topology to execute this scenario is shown below.

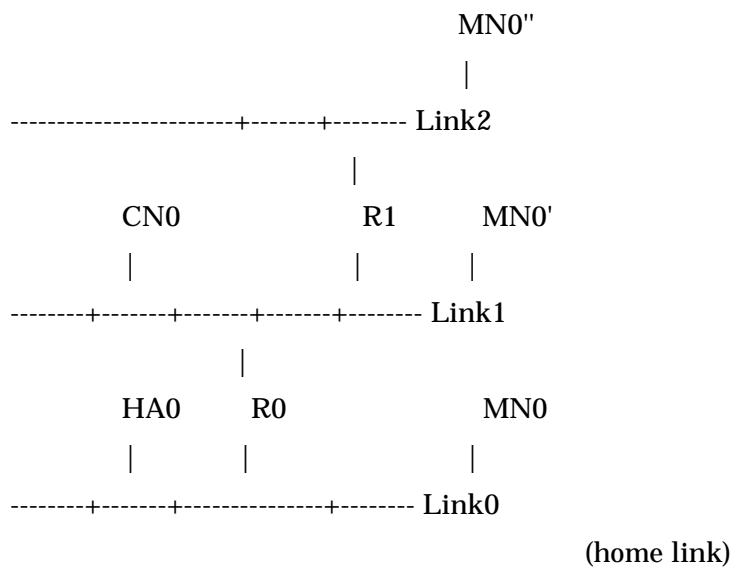

<<Link Information>>

-Link0

3ffe:501:fff:100::/64

home link

-Link1

3ffe:501:fff:101::/64

Foreign link

-Link2

3ffe:501:ffff:102::/64

Foreign link

<<Node Information>>

-HA0(Link0)

3ffe:501:ffff:100::200

-MN0(Link0)

3ffe:501:ffff:100::(Interface id) or 3ffe:501:ffff:100::300

Home address

-MN0'(Link1)

3ffe:501:ffff:101::(Interface id)

Care-of address

-MN0"(Link2)

3ffe:501:ffff:102::(Interface id)

Care-of address

-R0(Link0)

3ffe:501:ffff:100::1

-R0(Link1)

3ffe:501:ffff:101::1

-R1(Link1)

3ffe:501:ffff:101::2

-R1(Link2)

3ffe:501:ffff:102::2

-CN0(Link1)

3ffe:501:ffff:101::100

## 4.2 Test Initial conditions

In order to execute this scenario, the following Initial conditions should be satisfied.

### (1)CN0

- Have Binding Cache Entry for MN0.

### (2)HA0

- Have Binding Cache Entry for MN0.
- The following set-up be configured.
  - o IPsec : (ref. Appendix B)

### (3)MN0

- Have Binding List Entry for HA0.
- Have Binding List Entry for CN0.
- The following set-up be configured.
  - o HoA(Home Address) : (manual configuration or stateless address autoconfiguration)
  - o HA Address : N/A
  - o CoA(Care-of Address) : (stateful or stateless address autoconfiguration)
  - o IPsec : (ref. Appendix B)

## 5. Test Procedure

### 5.1 Procedure

The procedure to execute this scenario is stated as follows.

<<Procedure>>

<No>1

<Procedure> Continuously running ping6 command to HoA of MN0 under CN0  
(ref. 6.Judgement)

## 5.2 Related Mobile IPv6 sequences

The following is expected Mobile IPv6 sequence under the actual execution of this scenario.

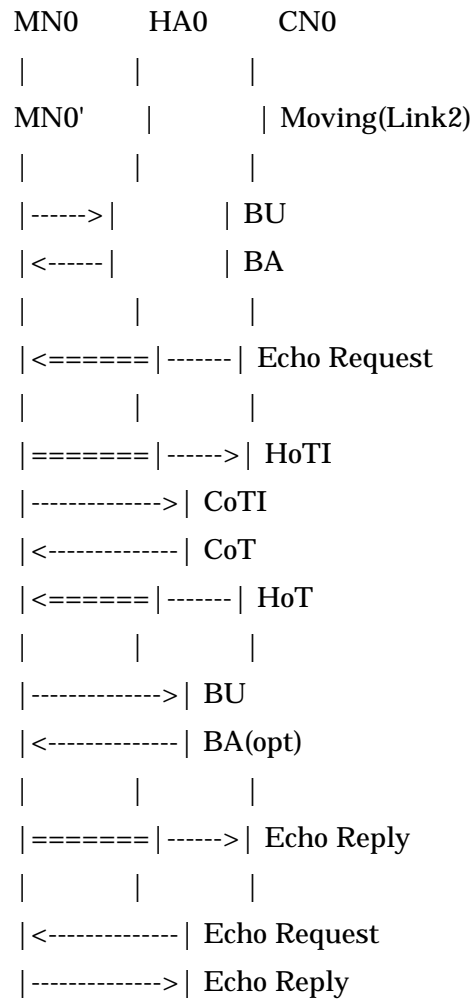

## 6. Judgement

- (1)Both Echo Request/Echo Reply should be received and sent between MN0 and CN0.
- (2)The route between MN0 and CN0 should be optimized.

Check-up procedure

e.g.)

- Execute "tracert6" to HoA of MN0 under CN0
  - Route display procedure : CN0 -> CoA of MN0 -> HoA of MN0
- MN0's Binding Cache entry should be created in HA0.
- MN0's Binding Cache entry should be created in CN0.
- HA0's Binding Update List entry should be created in MN0.
- CN0's Binding Update List entry should be created in MN0.
- Packet of MN0 and CN0 after Route Optimization (use tcpdump etc)
  - Type2 Routing Header should be attached to Echo Request of CN0 ->MN0
  - Home Address Option should be attached to Echo Reply of MN0 -> CN0

## 1-4-3-4

### 1. Name of Basic Scenario

1-4-3-4 Operation check starting from MN's foreign link to foreign link moving to the confirmation of communication between MN and CN.

(Communication between MN and CN, Route Optimization, moving)

### 2. Purpose & Outline

To check the consecutive operation, starting from MN's foreign link to foreign link moving to the confirmation of communication between MN and CN.

Test requirements for this scenario are listed as follows.

CN Route Optimization	: ON
MN Route Optimization	: ON
State of the MN	: Moving
Location of the MN	
Initial Network	: Foreign1
Last Network	: Foreign2
HA Address of the MN	: N/A
Direction of Communication	: MN->CN
IPsec	: ON (transport mode, tunnel mode)
IKE	: OFF

### 3. Resource Requirement

Requirements for Mobile IPv6 Node are listed as follows.

<<Requirement and Reference>>

<Device>      CN

<Requirement> Not in particular

<Reference>(Responding to Implementation Guideline)

- Payload Packets
  - 9.3.1 item No.3 - 9.3.1 item No.4
  - 9.3.1 item No.8
  - 9.3.2 item No.15 - 9.3.2 item No.16
- Route Optimization
  - 9.4.1 item No.1 - 9.4.4 item No.8
- CN Registration
  - 9.5.1 item No.1 - 9.5.1 item No.25,
  - 9.5.2 item No.26 - 9.5.2 item No.31,
  - 9.5.4 item No.35 - 9.5.4 item No.48

<Device> HA

<Requirement> Not in particular

<Reference>(Responding to Implementation Guideline)

- Registration
  - 10.3.1 item No.1 - 10.3.1 item No.39
- Payload Packets
  - 10.4.1 item No.1 - 10.4.1 item No.30
  - 10.4.5 item No.40 - 10.4.5 item No.43
- Route Optimization
  - 10.4.6 item No.44 - 10.4.6 item No.47

<Device> MN

<Requirement>- being equipped with the function of stateful or stateless address autoconfiguration and under the foreign link, Care-of address should be assigned.

<Reference>(Responding to Implementation Guideline)

- Registration
  - 11.7.1 item No.1 - item No.25,
  - 11.7.3 item No.50 - item No.61,
  - 4.2 item 11 - item 19,
  - 4.3 item 20 - item 22
- Payload Packets
  - 11.3 item No.34 - 11.3 item No.36

- Route Optimization

11.3.1 item No.9 - item No.13

11.6.1 item No.1 - item No.9

11.6.2 item No.10 - item No.25

11.6.3 item No.26 - item No.28

- CN Registration

11.7.1 item No.1 - item No.25,

11.7.3 item No.50 - 11.7.3 item No.61

#### 4. Test Setup

##### 4.1 Topology

The topology to execute this scenario is shown below.

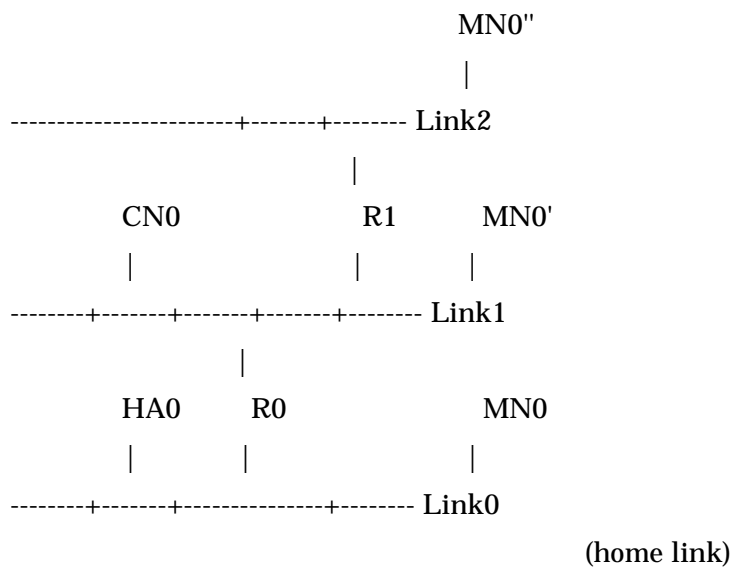

<<Link Information>>

-Link0

3ffe:501:fff:100::/64

home link

-Link1

3ffe:501:fff:101::/64

Foreign link

-Link2

3ffe:501:ffff:102::/64

Foreign link

<<Node Information>>

-HA0(Link0)

3ffe:501:ffff:100::200

-MN0(Link0)

3ffe:501:ffff:100::(Interface id) or 3ffe:501:ffff:100::300

Home address

-MN0'(Link1)

3ffe:501:ffff:101::(Interface id)

Care-of address

-MN0"(Link2)

3ffe:501:ffff:102::(Interface id)

Care-of address

-R0(Link0)

3ffe:501:ffff:100::1

-R0(Link1)

3ffe:501:ffff:101::1

-R1(Link1)

3ffe:501:ffff:101::2

-R1(Link2)

3ffe:501:ffff:102::2

-CN0(Link1)

3ffe:501:ffff:101::100

## 4.2 Test Initial conditions

In order to execute this scenario, the following Initial conditions should be satisfied.

### (1)CN0

- Have Binding Cache Entry for MN0.

### (2)HA0

- Have Binding Cache Entry for MN0.
- The following set-up be configured.
  - o IPsec : (ref. Appendix B)

### (3)MN0

- Have Binding List Entry for HA0.
- Have Binding List Entry for CN0.
- The following set-up be configured.
  - o HoA(Home Address) : (manual configuration or stateless address autoconfiguration)
  - o HA Address : N/A
  - o CoA(Care-of Address) : (stateful or stateless address autoconfiguration)
  - o IPsec : (ref. Appendix B)

## 5. Test Procedure

### 5.1 Procedure

The procedure to execute this scenario is stated as follows.

<<Procedure>>

<No>1

<Procedure> Move MN0 from Link1 to Link2

(Move to next link before binding cache entry expiration)

<No>2

<Procedure> Continuously running ping6 command to CN0 under MN0

(ref. 6.Judgement)

## 5.2 Related Mobile IPv6 sequences

The following is expected Mobile IPv6 sequence under the actual execution of this scenario.

MN0'	HA0	CN0
MN0''		Moving(Link1 -> Link2)
----->		BU
<-----		BA
===== ----->		HoTI
----->		CoTI
<-----		CoT
<===== -----		HoT
----->		BU
<-----		BA(opt)
===== ----->		Echo Request
<===== -----		Echo Reply

## 6. Judgement

- (1)Both Echo Request/Echo Reply should be received and sent between MN0 and CN0.
- (2)The route between MN0 and CN0 should be optimized.

Check-up procedure

e.g.)

- Execute "tracert6" to HoA of MN0 under CN0
  - Route display procedure : CN0 -> CoA of MN0 -> HoA of MN0
- MN0's Binding Cache entry should be created in HA0.
- MN0's Binding Cache entry should be created in CN0.
- HA0's Binding Update List entry should be created in MN0.
- CN0's Binding Update List entry should be created in MN0.
- Packet of MN0 and CN0 after Route Optimization (use tcpdump etc)
  - Type2 Routing Header should be attached to Echo Request of CN0 ->MN0
  - Home Address Option should be attached to Echo Reply of MN0 -> CN0

## 1-4-3-5

### 1. Name of Basic Scenario

1-4-3-5 Operation check starting from MN's foreign link to foreign link moving to the confirmation of communication between MN and CN.

(Communication between MN and CN, Route Optimization, moving)

### 2. Purpose & Outline

To check the consecutive operation, starting from MN's foreign link to foreign link moving to the confirmation of communication between MN and CN.

Test requirements for this scenario are listed as follows.

CN Route Optimization	: ON
MN Route Optimization	: ON
State of the MN	: Moving
Location of the MN	
Initial Network	: Foreign1
Last Network	: Foreign2
HA Address of the MN	: N/A
Direction of Communication	: CN->MN
IPsec	: ON (transport mode, tunnel mode)
IKE	: OFF

### 3. Resource Requirement

Requirements for Mobile IPv6 Node are listed as follows.

<<Requirement and Reference>>

<Device>      CN

<Requirement> Not in particular

<Reference>(Responding to Implementation Guideline)

- Payload Packets
  - 9.3.1 item No.3 - 9.3.1 item No.4
  - 9.3.1 item No.8
  - 9.3.2 item No.15 - 9.3.2 item No.16
- Route Optimization
  - 9.4.1 item No.1 - 9.4.4 item No.8
- CN Registration
  - 9.5.1 item No.1 - 9.5.1 item No.25,
  - 9.5.2 item No.26 - 9.5.2 item No.31,
  - 9.5.4 item No.35 - 9.5.4 item No.48

<Device> HA

<Requirement> Not in particular

<Reference>(Responding to Implementation Guideline)

- Registration
  - 10.3.1 item No.1 - 10.3.1 item No.39
- Payload Packets
  - 10.4.1 item No.1 - 10.4.1 item No.30
  - 10.4.5 item No.40 - 10.4.5 item No.43
- Route Optimization
  - 10.4.6 item No.44 - 10.4.6 item No.47

<Device> MN

<Requirement>- being equipped with the function of stateful or stateless address autoconfiguration and under the foreign link, Care-of address should be assigned.

<Reference>(Responding to Implementation Guideline)

- Registration
  - 11.7.1 item No.1 - item No.25,
  - 11.7.3 item No.50 - item No.61,
  - 4.2 item 11 - item 19,
  - 4.3 item 20 - item 22
- Payload Packets
  - 11.3 item No.34 - 11.3 item No.36

- Route Optimization

11.3.1 item No.9 - item No.13

11.6.1 item No.1 - item No.9

11.6.2 item No.10 - item No.25

11.6.3 item No.26 - item No.28

- CN Registration

11.7.1 item No.1 - item No.25,

11.7.3 item No.50 - 11.7.3 item No.61

#### 4. Test Setup

##### 4.1 Topology

The topology to execute this scenario is shown below.

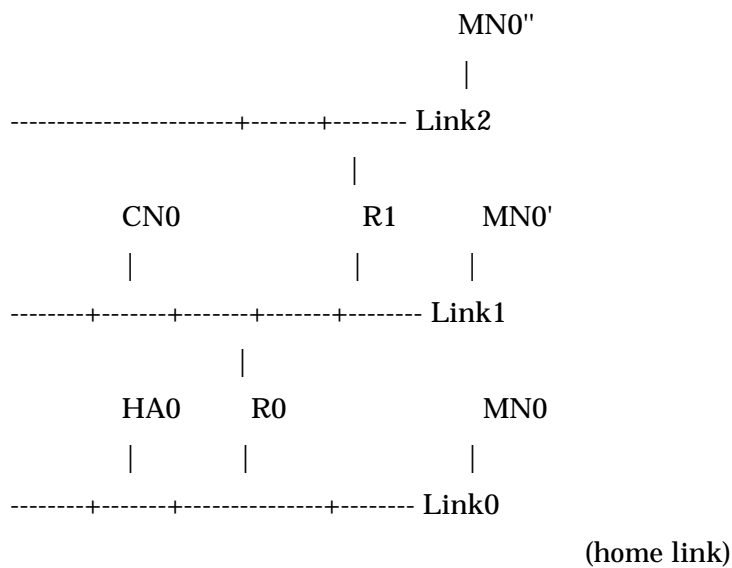

<<Link Information>>

-Link0

3ffe:501:fff:100::/64

home link

-Link1

3ffe:501:fff:101::/64

Foreign link

-Link2

3ffe:501:ffff:102::/64

Foreign link

<<Node Information>>

-HA0(Link0)

3ffe:501:ffff:100::200

-MN0(Link0)

3ffe:501:ffff:100::(Interface id) or 3ffe:501:ffff:100::300

Home address

-MN0'(Link1)

3ffe:501:ffff:101::(Interface id)

Care-of address

-MN0"(Link2)

3ffe:501:ffff:102::(Interface id)

Care-of address

-R0(Link0)

3ffe:501:ffff:100::1

-R0(Link1)

3ffe:501:ffff:101::1

-R1(Link1)

3ffe:501:ffff:101::2

-R1(Link2)

3ffe:501:ffff:102::2

-CN0(Link1)

3ffe:501:ffff:101::100

## 4.2 Test Initial conditions

In order to execute this scenario, the following Initial conditions should be satisfied.

### (1)CN0

- Have Binding Cache Entry for MN0.

### (2)HA0

- Have Binding Cache Entry for MN0.
- The following set-up be configured.
  - o IPsec : (ref. Appendix B)

### (3)MN0

- Have Binding List Entry for HA0.
- Have Binding List Entry for CN0.
- The following set-up be configured.
  - o HoA(Home Address) : (manual configuration or stateless address autoconfiguration)
  - o HA Address : N/A
  - o CoA(Care-of Address) : (stateful or stateless address autoconfiguration)
  - o IPsec : (ref. Appendix B)

## 5. Test Procedure

### 5.1 Procedure

The procedure to execute this scenario is stated as follows.

<<Procedure>>

<No>1

<Procedure> Move MN0 from Link1 to Link2

(Move to next link before binding cache entry expiration)

<No>2

<Procedure> Continuously running ping6 command to HoA of MN0 under CN0

(ref. 6.Judgement)

## 5.2 Related Mobile IPv6 sequences

The following is expected Mobile IPv6 sequence under the actual execution of this scenario.

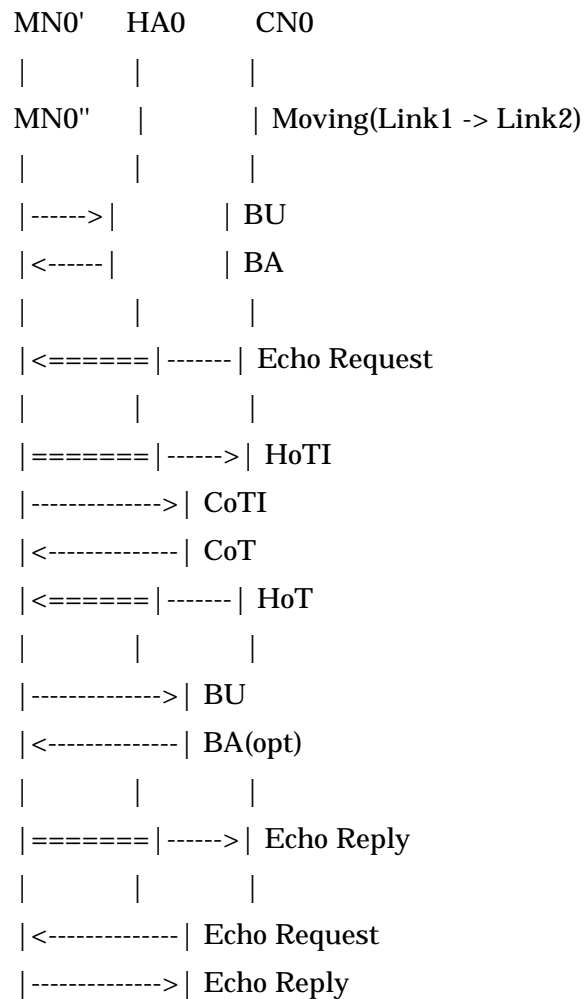

## 6. Judgement

- (1)Both Echo Request/Echo Reply should be received and sent between MN0 and CN0.
- (2)The route between MN0 and CN0 should be optimized.

## Check-up procedure

e.g.)

- Execute "traceroute6" to HoA of MN0 under CN0
  - Route display procedure : CN0 -> CoA of MN0 -> HoA of MN0
- MN0's Binding Cache entry should be created in HA0.
- MN0's Binding Cache entry should be created in CN0.
- HA0's Binding Update List entry should be created in MN0.
- CN0's Binding Update List entry should be created in MN0.
- Packet of MN0 and CN0 after Route Optimization (use tcpdump etc)
  - Type2 Routing Haeder should be attached to Echo Request of CN0 ->MN0
  - Home Address Option should be attached to Echo Reply of MN0 -> CN0

## 1-4-3-7

### 1. Name of Basic Scenario

1-4-3-7 Operation check starting from MN's foreign link to home link moving to the confirmation of communication between MN and CN.

(Communication between MN and CN, Route Optimization, moving)

### 2. Purpose & Outline

To check the consecutive operation, starting from MN's foreign link to home link moving to the confirmation of communication between MN and CN.

Test requirements for this scenario are listed as follows.

CN Route Optimization	: ON
MN Route Optimization	: ON
State of the MN	: Moving
Location of the MN	
Initial Network	: Foreign
Last Network	: Home
HA Address of the MN	: N/A
Direction of Communication	: MN->CN
IPsec	: ON (transport mode, tunnel mode)
IKE	: OFF

### 3. Resource Requirement

Requirements for Mobile IPv6 Node are listed as follows.

<<Requirement and Reference>>

<Device>      CN

<Requirement> Not in particular

<Reference>(Responding to Implementation Guideline)

- Payload Packets
  - 9.3.1 item No.3 - 9.3.1 item No.4
  - 9.3.1 item No.8
  - 9.3.2 item No.15 - 9.3.2 item No.16
- Route Optimization
  - 9.4.1 item No.1 - 9.4.4 item No.8
- CN Registration
  - 9.5.1 item No.1 - 9.5.1 item No.25,
  - 9.5.2 item No.26 - 9.5.2 item No.31,
  - 9.5.4 item No.35 - 9.5.4 item No.48

<Device> HA

<Requirement> Not in particular

<Reference>(Responding to Implementation Guideline)

- Registration
  - 10.3.1 item No.1 - 10.3.1 item No.39
- Payload Packets
  - 10.4.1 item No.1 - 10.4.1 item No.30
  - 10.4.5 item No.40 - 10.4.5 item No.43
- Route Optimization
  - 10.4.6 item No.44 - 10.4.6 item No.47

<Device> MN

<Requirement>- being equipped with the function of stateful or stateless address autoconfiguration and under the foreign link, Care-of address should be assigned.

<Reference>(Responding to Implementation Guideline)

- Registration
  - 11.7.1 item No.1 - item No.25,
  - 11.7.3 item No.50 - item No.61,
  - 4.2 item 11 - item 19,
  - 4.3 item 20 - item 22
- Payload Packets
  - 11.3 item No.34 - 11.3 item No.36

- Route Optimization

11.3.1 item No.9 - item No.13

11.6.1 item No.1 - item No.9

11.6.2 item No.10 - item No.25

11.6.3 item No.26 - item No.28

- CN Registration

11.7.1 item No.1 - item No.25,

11.7.3 item No.50 - 11.7.3 item No.61

#### 4. Test Setup

##### 4.1 Topology

The topology to execute this scenario is shown below.

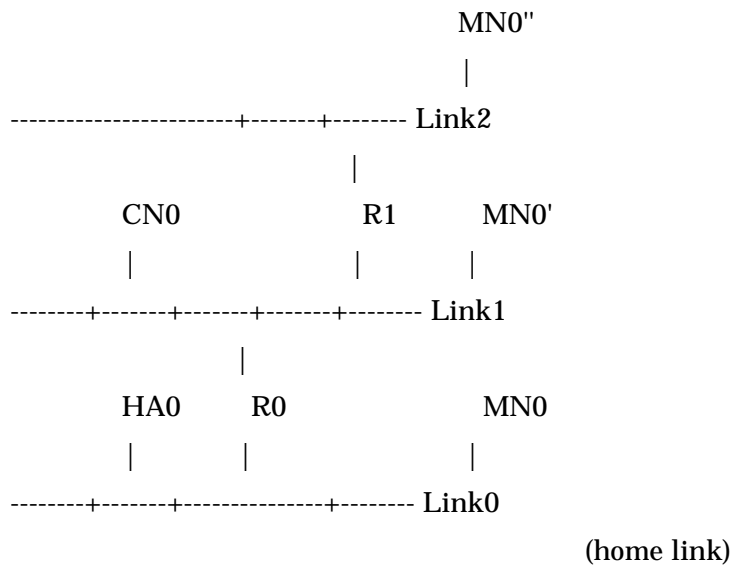

<<Link Information>>

-Link0

3ffe:501:fff:100::/64

home link

-Link1

3ffe:501:fff:101::/64

Foreign link

-Link2

3ffe:501:ffff:102::/64

Foreign link

<<Node Information>>

-HA0(Link0)

3ffe:501:ffff:100::200

-MN0(Link0)

3ffe:501:ffff:100::(Interface id) or 3ffe:501:ffff:100::300

Home address

-MN0'(Link1)

3ffe:501:ffff:101::(Interface id)

Care-of address

-MN0"(Link2)

3ffe:501:ffff:102::(Interface id)

Care-of address

-R0(Link0)

3ffe:501:ffff:100::1

-R0(Link1)

3ffe:501:ffff:101::1

-R1(Link1)

3ffe:501:ffff:101::2

-R1(Link2)

3ffe:501:ffff:102::2

-CN0(Link1)

3ffe:501:ffff:101::100

## 4.2 Test Initial conditions

In order to execute this scenario, the following Initial conditions should be satisfied.

### (1)CN0

- Have Binding Cache Entry for MN0.

### (2)HA0

- Have Binding Cache Entry for MN0.
- The following set-up be configured.
  - o IPsec : (ref. Appendix B)

### (3)MN0

- Have Binding List Entry for HA0.
- Have Binding List Entry for CN0.
- The following set-up be configured.
  - o HoA(Home Address) : (manual configuration or stateless address autoconfiguration)
  - o HA Address : N/A
  - o CoA(Care-of Address) : (stateful or stateless address autoconfiguration)
  - o IPsec : (ref. Appendix B)

## 5. Test Procedure

### 5.1 Procedure

The procedure to execute this scenario is stated as follows.

<<Procedure>>

<No>1

<Procedure> Move MN0 from Link2 to Link0

(Move to next link before binding cache entry expiration)

<No>2

<Procedure> Continuously running ping6 command to CN0 under MN0

(ref. 6.Judgement)

## 5.2 Related Mobile IPv6 sequences

The following is expected Mobile IPv6 sequence under the actual execution of this scenario.

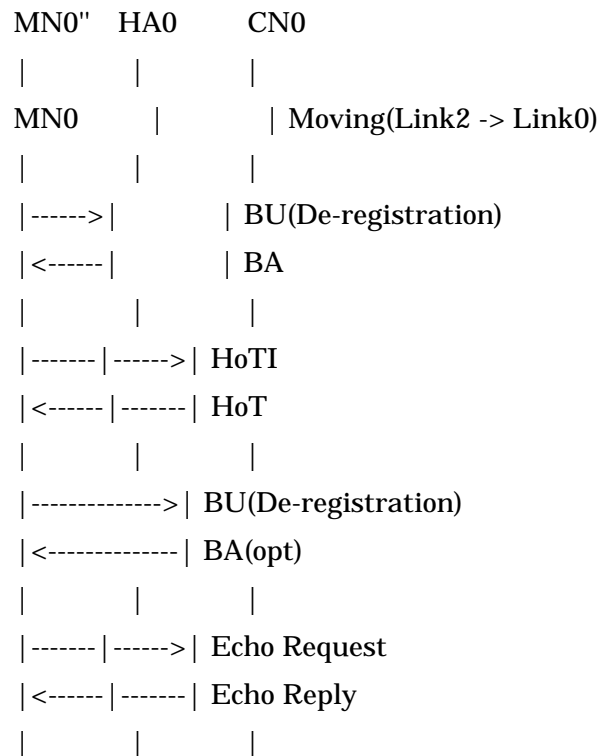

## 6. Judgement

- (1)Both Echo Request/Echo Reply should be received and sent between MN0 and CN0.
- (2)The route between MN0 and CN0 should be optimized.

Check-up procedure

e.g.)

- Execute "tracert6" to HoA of MN0 under CN0

Route display procedure : CN0 -> CoA of MN0 -> HoA of MN0

- MN0's Binding Cache entry should be created in HA0.
- MN0's Binding Cache entry should be created in CN0.
- HA0's Binding Update List entry should be created in MN0.
- CN0's Binding Update List entry should be created in MN0.
- Packet of MN0 and CN0 after Route Optimization (use tcpdump etc)
  - Type2 Routing Haeder should be attached to Echo Request of CN0 ->MN0
  - Home Address Option should be attached to Echo Reply of MN0 -> CN0

## 1-4-3-8

### 1. Name of Basic Scenario

1-4-3-8 Operation check starting from MN's foreign link to home link moving to the confirmation of communication between MN and CN.

(Communication between MN and CN, Route Optimization, moving)

### 2. Purpose & Outline

To check the consecutive operation, starting from MN's foreign link to home link moving to the confirmation of communication between MN and CN.

Test requirements for this scenario are listed as follows.

CN Route Optimization	: ON
MN Route Optimization	: ON
State of the MN	: Moving
Location of the MN	
Initial Network	: Foreign
Last Network	: Home
HA Address of the MN	: N/A
Direction of Communication	: CN->MN
IPsec	: ON (transport mode, tunnel mode)
IKE	: OFF

### 3. Resource Requirement

Requirements for Mobile IPv6 Node are listed as follows.

<<Requirement and Reference>>

<Device>      CN

<Requirement> Not in particular

<Reference>(Responding to Implementation Guideline)

- Payload Packets
  - 9.3.1 item No.3 - 9.3.1 item No.4
  - 9.3.1 item No.8
  - 9.3.2 item No.15 - 9.3.2 item No.16
- Route Optimization
  - 9.4.1 item No.1 - 9.4.4 item No.8
- CN Registration
  - 9.5.1 item No.1 - 9.5.1 item No.25,
  - 9.5.2 item No.26 - 9.5.2 item No.31,
  - 9.5.4 item No.35 - 9.5.4 item No.48

<Device> HA

<Requirement> Not in particular

<Reference>(Responding to Implementation Guideline)

- Registration
  - 10.3.1 item No.1 - 10.3.1 item No.39
- Payload Packets
  - 10.4.1 item No.1 - 10.4.1 item No.30
  - 10.4.5 item No.40 - 10.4.5 item No.43
- Route Optimization
  - 10.4.6 item No.44 - 10.4.6 item No.47

<Device> MN

<Requirement>- being equipped with the function of stateful or stateless address autoconfiguration and under the foreign link, Care-of address should be assigned.

<Reference>(Responding to Implementation Guideline)

- Registration
  - 11.7.1 item No.1 - item No.25,
  - 11.7.3 item No.50 - item No.61,
  - 4.2 item 11 - item 19,
  - 4.3 item 20 - item 22
- Payload Packets
  - 11.3 item No.34 - 11.3 item No.36

- Route Optimization

11.3.1 item No.9 - item No.13

11.6.1 item No.1 - item No.9

11.6.2 item No.10 - item No.25

11.6.3 item No.26 - item No.28

- CN Registration

11.7.1 item No.1 - item No.25,

11.7.3 item No.50 - 11.7.3 item No.61

#### 4. Test Setup

##### 4.1 Topology

The topology to execute this scenario is shown below.

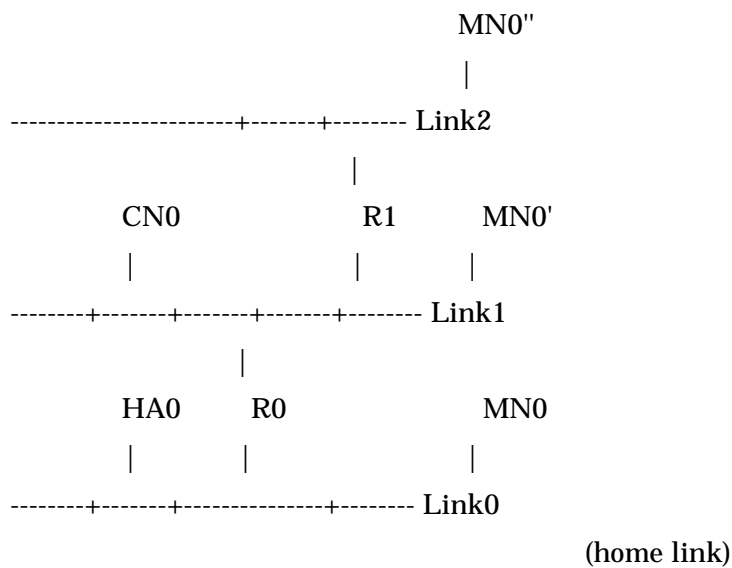

<<Link Information>>

-Link0

3ffe:501:fff:100::/64

home link

-Link1

3ffe:501:fff:101::/64

Foreign link

-Link2

3ffe:501:ffff:102::/64

Foreign link

<<Node Information>>

-HA0(Link0)

3ffe:501:ffff:100::200

-MN0(Link0)

3ffe:501:ffff:100::(Interface id) or 3ffe:501:ffff:100::300

Home address

-MN0'(Link1)

3ffe:501:ffff:101::(Interface id)

Care-of address

-MN0"(Link2)

3ffe:501:ffff:102::(Interface id)

Care-of address

-R0(Link0)

3ffe:501:ffff:100::1

-R0(Link1)

3ffe:501:ffff:101::1

-R1(Link1)

3ffe:501:ffff:101::2

-R1(Link2)

3ffe:501:ffff:102::2

-CN0(Link1)

3ffe:501:ffff:101::100

## 4.2 Test Initial conditions

In order to execute this scenario, the following Initial conditions should be satisfied.

### (1)CN0

- Have Binding Cache Entry for MN0.

### (2)HA0

- Have Binding Cache Entry for MN0.
- The following set-up be configured.
  - o IPsec : (ref. Appendix B)

### (3)MN0

- Have Binding List Entry for HA0.
- Have Binding List Entry for CN0.
- The following set-up be configured.
  - o HoA(Home Address) : (manual configuration or stateless address autoconfiguration)
  - o HA Address : N/A
  - o CoA(Care-of Address) : (stateful or stateless address autoconfiguration)
  - o IPsec : (ref. Appendix B)

## 5. Test Procedure

### 5.1 Procedure

The procedure to execute this scenario is stated as follows.

<<Procedure>>

<No>1

<Procedure> Move MN0 from Link2 to Link0

(Move to next link before binding cache entry expiration)

<No>2

<Procedure> Continuously running ping6 command to HoA of MN0 under CN0

(ref. 6.Judgement)

## 5.2 Related Mobile IPv6 sequences

The following is expected Mobile IPv6 sequence under the actual execution of this scenario.

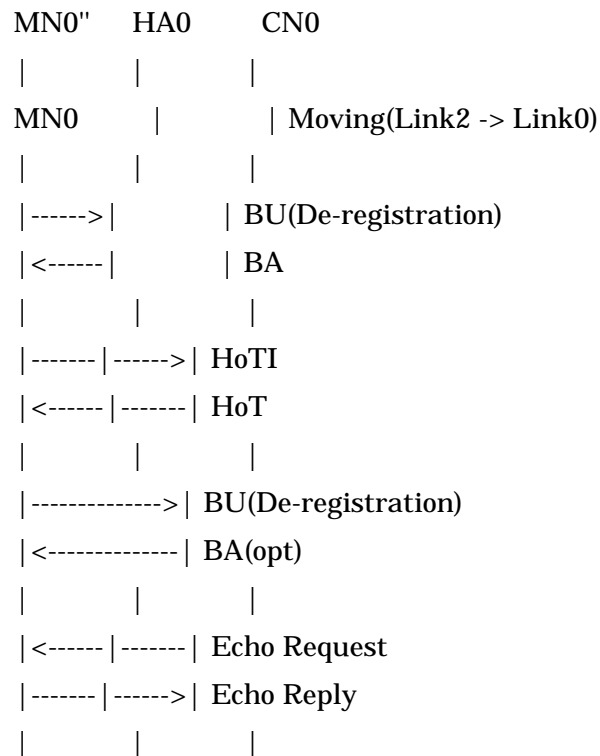

## 6. Judgement

- (1)Both Echo Request/Echo Reply should be received and sent between MN0 and CN0.
- (2)The route between MN0 and CN0 should be optimized.

### Check-up procedure

e.g.)

- Execute "traceroute6" to HoA of MN0 under CN0  
Route display procedure : CN0 -> CoA of MN0 -> HoA of MN0
- MN0's Binding Cache entry should be created in HA0.

- MN0's Binding Cache entry should be created in CN0.
- HA0's Binding Update List entry should be created in MN0.
- CN0's Binding Update List entry should be created in MN0.
- Packet of MN0 and CN0 after Route Optimization (use tcpdump etc)
  - Type2 Routing Haeder should be attached to Echo Request of CN0 ->MN0
  - Home Address Option should be attached to Echo Reply of MN0 -> CN0

# <A2B-HAHA-1>

## 1. Name of Interoperability Test Scenario

A2B-HAHA-1 Communication between HA and HA, using DHAAD.

## 2. Purpose & Outline

Each HA transmits RA and exchanges Home Agents List.

This test verifies that the HA manages Home Agents List correctly, and the MN can select an applicable HA from the Home Agents List received by DHAAD.

- Several HAs have a same home link.
- MNs also have a same home link.

## 3. Test Setup

### 3.1 Topology

The topology to execute this scenario is shown below.

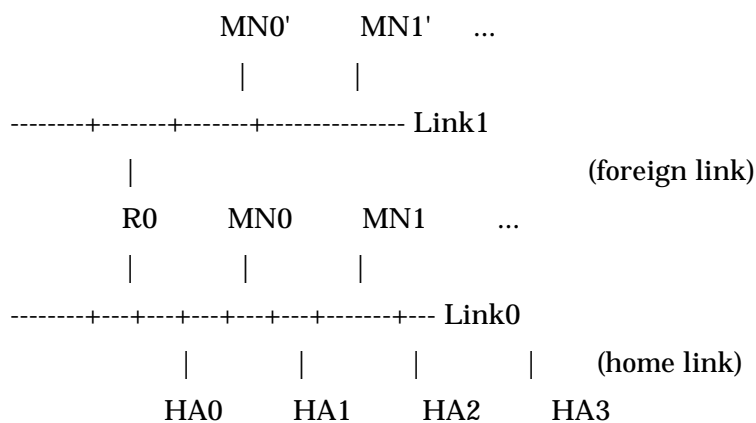

<<Link Information>>

-Link0

3ffe:501:ffff:100::/64

home link

-Link1

3ffe:501:ffff:101::/64

foreign link

<<Node Information>>

-HA0

3ffe:501:ffff:100::200

-HA1

3ffe:501:ffff:100::201

-HA2

3ffe:501:ffff:100::202

-HA3

3ffe:501:ffff:100::203

-MN0(Link0)

3ffe:501:ffff:100::(Interface id) or 3ffe:501:ffff:100::300

Home address

-MN0'(Link1)

3ffe:501:ffff:101::(Interface id)

Care-of address

-MN1(Link0)

3ffe:501:ffff:100::(Interface id) or 3ffe:501:ffff:100::301

Home address

-MN1'(Link1)

3ffe:501:ffff:101::(Interface id)

Care-of address

...

-R0(Link0)

3ffe:501:ffff:100::1

-R0(Link1)

3ffe:501:ffff:101::1

### 3.2 Test Initial conditions

In order to execute this scenario, the following Initial condition should be satisfied.

#### (a) MNs

- Does not have Binding List Entry for all HAs.
- The following set-up be configured.
  - o HoA(Home Address) : (manual configuration or stateless address autoconfiguration)
  - o HA Address : DHAAD
  - o Care-of Address : (stateful or stateless address autoconfiguration)
  - o IPsec : (ref. Appendix B)

#### (b) HAs

- Does not have Binding Cache Entry for all MNs.
- The following set-up be configured.
  - o IPsec : (ref. Appendix B)

## 4. Test Procedure

### 4.1 Procedure

The procedure to execute this scenario is stated as follows.

<<Procedure>>

case	HA0	HA1	HA2	HA3
a)	0	1	2	3*
b)	3*	0	1	2
c)	2	3*	0	1
d)	1	2	3*	0
e)	0	0	1*	1*

Table 1. home agent preference  
(\* means the highest preference)

<No>1 Initialize

<No>1-1

<Procedure> set preference case a) to HAs as described for each case.

<No>2 Verify that HA0 can reply DHAAD reply

<No>2-1

<Procedure> Confirm HA list on each HAs.

NA list should be listed by the preference specified in Table 1.

<No>2-2

<Procedure> Detach HAs other than HA0

<No>2-3

<Procedure> Reboot up all MNs at Link1

<No>2-4

<Procedure> Wait the DHAAD request and home registration.

<No>2-5

<Procedure> Attach HAs

<No>3 Verify that HA1 can reply DHAAD reply

<No>3-1

<Procedure> Confirm HA list on each HAs.

NA list should be listed by the preference specified in Table 1.

<No>3-2

<Procedure> Detach HAs other than HA1

<No>3-3

<Procedure> Reboot up all MNs at Link1

<No>3-4

<Procedure> Wait the DHAAD request and home registration.

<No>3-5

<Procedure> Attach HAs

<No>4 Verify that HA2 can reply DHAAD reply

<No>4-1

<Procedure> Confirm HA list on each HAs.

NA list should be listed by the preference specified in Table 1.

<No>4-2

<Procedure> Detach HAs other than HA2

<No>4-3

<Procedure> Reboot up all MNs at Link1

<No>4-4

<Procedure> Wait the DHAAD request and home registration.

<No>4-5

<Procedure> Attach HAs

<No>5 Verify that HA3 can reply DHAAD reply

<No>5-1

<Procedure> Confirm HA list on each HAs.

NA list should be listed by the preference specified in Table 1.

<No>5-2

<Procedure> Detach HAs other than HA3

<No>5-3

<Procedure> Reboot up all MNs at Link1

<No>5-4

<Procedure> Wait the DHAAD request and home registration.

<No>5-5

<Procedure> Attach HAs

<No>6 Repeat Steps <No>1 through <No>5 for case b) through e) in Table 1.

## <A2B-MN-MN-2>

### 1. Name of Interoperability Test Scenario

A2B-MN-MN-2 Communication between MNs sharing single HA using bidirectional RO, DHAAD.

### 2. Purpose & Outline

2 MN Groups, booted up on a Foreign link, move to different Foreign links or same Foreign link with following condition. MN communicates with other MNs.

- MNs perform Route Optimization
- MNs perform DHAAD (single HA)
- MNs share single HA
- MNG0 consists with Multiple MNs, as an example we define MNa and MNb as the member of MNG0
- MNG1 consists with Multiple MNs, as an example we define MNc and MNd as the member of MNG1

### 3. Test Setup

#### 3.1 Topology

The topology to execute this scenario is shown below.

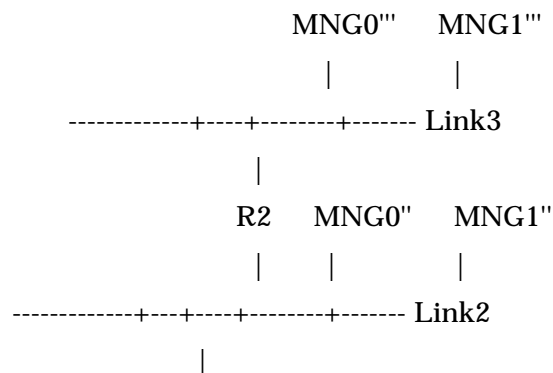

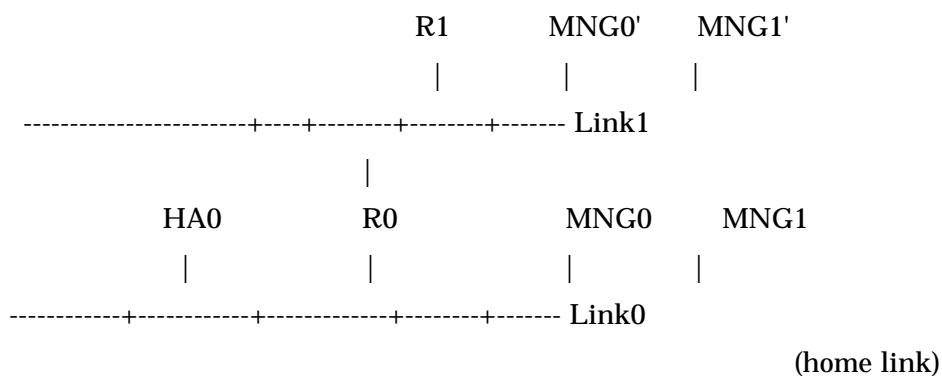

<<Link Information>>

-Link0

3ffe:501:ffff:100::/64

home link

-Link1

3ffe:501:ffff:101::/64

foreign link

-Link2

3ffe:501:ffff:102::/64

foreign link

-Link3

3ffe:501:ffff:103::/64

foreign link

<<Node Information>>

-HA0

3ffe:501:ffff:100::200

-MNG0(Link0)

3ffe:501:ffff:100::(Interface id)

Home address

-MNG0'(Link1)

3ffe:501:ffff:101::(Interface id)

Care-of address

-MNG0"(Link2)

3ffe:501:ffff:102::(Interface id)

Care-of address

-MNG0'"(Link3)

3ffe:501:ffff:103::(Interface id)

Care-of address

-MNG1(Link0)

3ffe:501:ffff:100::(Interface id)

Home address

-MNG1'(Link1)

3ffe:501:ffff:101::(Interface id)

Care-of address

-MNG1"(Link2)

3ffe:501:ffff:102::(Interface id)

Care-of address

-MNG1'"(Link3)

3ffe:501:ffff:103::(Interface id)

Care-of address

-R0(Link0)

3ffe:501:ffff:100::1

-R0(Link1)

3ffe:501:ffff:101::1

-R1(Link1)

3ffe:501:ffff:101::2

-R1(Link2)

3ffe:501:ffff:102::2

-R2(Link2)

3ffe:501:ffff:102::3

-R2(Link3)

3ffe:501:ffff:103::3

### 3.2 Test Initial conditions

In order to execute this scenario, the following Initial condition should be satisfied.

#### (a) MNG0

- Set HoA(3ffe:501:ffff:100::(Interface id)).
- Configure to perform DHAAD to get HA address.
- Configure to run Stateless address autoconfiguration to set CoA.
- Use IPsec as described in Appendix.
- Does not have Binding Cache Entry for MNG1.

#### (b) MNG1

- Set HoA(3ffe:501:ffff:100::(Interface id)).
- Configure to perform DHAAD to get HA address.
- Configure to run Stateless address autoconfiguration to set CoA.
- Use IPsec as described in Appendix.
- Does not have Binding Cache Entry for MNG0.

#### (c) HA0

- Does not have Binding Cache Entry for MNG0.
- Use IPsec as described in Appendix.

### 4. Test Procedure

## 4.1 Procedure

The procedure to execute this scenario is stated as follows.

<<Procedure>>

Networks where the Mobile Nodes attach at the end of each case.

\*: means perform ping.

### Case-A) Ping Direction (MNG0 to MNG1)

	To	MNa	MNb	MNc	MNd
From					
MNa	N/A		*		
MNb		N/A		*	
MNc			N/A		
MNd				N/A	

### Case-B) Ping Direction (MNG0 to MNG1 Mesh)

	To	MNa	MNb	MNc	MNd
From					
MNa	N/A		*	*	
MNb		N/A	*	*	
MNc			N/A		
MNd				N/A	

### Case-C) Ping Direction (MNG0 to MNG0 and MNG1 Mesh)

	To	MNa	MNb	MNc	MNd
From					

	MNa	MNb	MNc	MNd
MNa	N/A	*	*	*
MNb	*	N/A	*	*
MNc			N/A	
MNd				N/A

**Case-D) Ping Direction (MNG1 to MNG0)**

	To	MNa	MNb	MNc	MNd
From					
MNa	N/A				
MNb			N/A		
MNc	*			N/A	
MNd			*		N/A

**Case-E) Ping Direction (MNG1 to MNG0 Mesh)**

	To	MNa	MNb	MNc	MNd
From					
MNa	N/A				
MNb			N/A		
MNc	*	*		N/A	
MNd	*	*			N/A

**Case-F) Ping Direction (MNG1 to MNG0 and MNG1 Mesh)**

	To	MNa	MNb	MNc	MNd
From					
MNa	N/A				
MNb			N/A		

MNc	*	*	N/A	*
MNd	*	*	*	N/A

**Movement talbe**

step	Link0	Link1	Link2	Link3
1)		MNG0/MNG1		(Booting-up)
2)			MNG0	MNG1
3)			MNG1	MNG0
4)		MNG0/MNG1		
5)			MNG0/MNG1	

<No>1 Boot up both Groups on same Link

<No>1-1

<Procedure> Boot up MNG0 on Link1(MNG0').

<No>1-2

<Procedure> Boot up MNG1 on Link1(MNG1').

<No>1-3

<Procedure> Repeat ping MNG0'->MNG1' until <No>5-3.

The pair of ping is described in Table Case-A.

<No>2 Move from same link to diffent Links

<No>2-1

<Procedure> Move MNG0' from Link1(MNG0') to Link2(MN0G'')

(Move to next link before BCE expiration)

<No>2-2

<Procedure> Move MNG1' from Link1(MNG1') to Link3(MN1G''')

(Move to next link before BCE expiration)

\*Do <No>2-1 and <No>2-2 at the same time as far as possible.

<No>3 Move from different links to different Links

<No>3-1

<Procedure> Move MNG0" from Link2(MNG0") to Link3(MN0G")  
(Move to next link before BCE expiration)

<No>3-2

<Procedure> Move MNG1"" from Link3(MNG1"") to Link2(MN1G")  
(Move to next link before BCE expiration)

\*Do <No>3-1 and <No>3-2 at the same time as far as possible.

<No>4 Move from different links to same link

<No>4-1

<Procedure> Move MNG0"" from Link3(MNG0"") to Link1(MN0G')  
(Move to next link before BCE expiration)

<No>4-2

<Procedure> Move MNG1" from Link2(MNG1") to Link1(MN1G')  
(Move to next link before BCE expiration)

\*Do <No>4-1 and <No>4-2 at the same time as far as possible.

<No>5 Move from same link to another same link

<No>5-1

<Procedure> Move MNG0' from Link1(MNG0') to Link2(MN0G")  
(Move to next link before BCE expiration)

<No>5-2

<Procedure> Move MNG1' from Link1(MNG1') to Link2(MN1G")  
(Move to next link before BCE expiration)

\*Do <No>5-1 and <No>5-2 at the same time as far as possible.

<No>5-3

<Procedure> Stop ping

<No>6 Boot up both Groups on same Link

<No>6-1

<Procedure> Boot up MNG0 on Link1(MNG0').

<No>6-2

<Procedure> Boot up MNG1 on Link1(MNG1').

<No>6-3

<Procedure> Repeat ping MNG0'->MNG1' until <No>10-3.

The pair of ping is described in Table Case-B.

<No>7 Move from same link to different Links

<No>7-1

<Procedure> Move MNG0' from Link1(MNG0') to Link2(MN0G'')

(Move to next link before BCE expiration)

<No>7-2

<Procedure> Move MNG1' from Link1(MNG1') to Link3(MN1G''')

(Move to next link before BCE expiration)

\*Do <No>7-1 and <No>7-2 at the same time as far as possible.

<No>8 Move from different links to different Links

<No>8-1

<Procedure> Move MNG0'' from Link2(MNG0'') to Link3(MN0G''')

(Move to next link before BCE expiration)

<No>8-2

<Procedure> Move MNG1''' from Link3(MNG1''') to Link2(MN1G'')  
(Move to next link before BCE expiration)

\*Do <No>8-1 and <No>8-2 at the same time as far as possible.

<No>9 Move from different links to same link

<No>9-1

<Procedure> Move MNG0''' from Link3(MNG0''') to Link1(MN0G')  
(Move to next link before BCE expiration)

<No>9-2

<Procedure> Move MNG1'' from Link2(MNG1'') to Link1(MN1G')  
(Move to next link before BCE expiration)

\*Do <No>9-1 and <No>9-2 at the same time as far as possible.

<No>10 Move from same link to another same link

<No>10-1

<Procedure> Move MNG0' from Link1(MNG0') to Link2(MN0G'')  
(Move to next link before BCE expiration)

<No>10-2

<Procedure> Move MNG1' from Link1(MNG1') to Link2(MN1G'')  
(Move to next link before BCE expiration)

\*Do <No>10-1 and <No>10-2 at the same time as far as possible.

<No>10-3

<Procedure> Stop ping

<No>11 Boot up both Groups on same Link

<No>11-1

<Procedure> Boot up MNG0 on Link1(MNG0').

<No>11-2

<Procedure> Boot up MNG1 on Link1(MNG1').

<No>11-3

<Procedure> Repeat ping MNG0'->MNG1' until <No>15-3.

The pair of ping is described in Table Case-C.

<No>12 Move from same link to different Links

<No>12-1

<Procedure> Move MNG0' from Link1(MNG0') to Link2(MN0G")

(Move to next link before BCE expiration)

<No>12-2

<Procedure> Move MNG1' from Link1(MNG1') to Link3(MN1G''')

(Move to next link before BCE expiration)

\*Do <No>12-1 and <No>12-2 at the same time as far as possible.

<No>13 Move from different links to different Links

<No>13-1

<Procedure> Move MNG0'' from Link2(MNG0'') to Link3(MN0G''')

(Move to next link before BCE expiration)

<No>13-2

<Procedure> Move MNG1''' from Link3(MNG1''') to Link2(MN1G'')

(Move to next link before BCE expiration)

\*Do <No>13-1 and <No>13-2 at the same time as far as possible.

<No>14 Move from different links to same link

<No>14-1

<Procedure> Move MNG0''' from Link3(MNG0''') to Link1(MN0G')

(Move to next link before BCE expiration)

<No>14-2

<Procedure> Move MNG1" from Link2(MNG1") to Link1(MN1G')

(Move to next link before BCE expiration)

\*Do <No>14-1 and <No>14-2 at the same time as far as possible.

<No>15     Move from same link to another same link

<No>15-1

<Procedure> Move MNG0' from Link1(MNG0') to Link2(MN0G")

(Move to next link before BCE expiration)

<No>15-2

<Procedure> Move MNG1' from Link1(MNG1') to Link2(MN1G")

(Move to next link before BCE expiration)

\*Do <No>15-1 and <No>15-2 at the same time as far as possible.

<No>15-3

<Procedure> Stop ping

<No>16     Boot up both Groups on same Link

<No>16-1

<Procedure> Boot up MNG0 on Link1(MNG0').

<No>16-2

<Procedure> Boot up MNG1 on Link1(MNG1').

<No>16-3

<Procedure> Repeat ping MNG1'->MNG0' until <No>20-3.

The pair of ping is described in Table Case-D

<No>17 Move from same link to different Links

<No>17-1

<Procedure> Move MNG0' from Link1(MNG0') to Link2(MN0G")  
(Move to next link before BCE expiration)

<No>17-2

<Procedure> Move MNG1' from Link1(MNG1') to Link3(MN1G")  
(Move to next link before BCE expiration)

\*Do <No>17-1 and <No>17-2 at the same time as far as possible.

<No>18 Move from different links to different Links

<No>18-1

<Procedure> Move MNG0" from Link2(MNG0") to Link3(MN0G")  
(Move to next link before BCE expiration)

<No>18-2

<Procedure> Move MNG1"" from Link3(MNG1"") to Link2(MN1G")  
(Move to next link before BCE expiration)

\*Do <No>18-1 and <No>18-2 at the same time as far as possible.

<No>19 Move from different links to same link

<No>19-1

<Procedure> Move MNG0"" from Link3(MNG0"") to Link1(MN0G')  
(Move to next link before BCE expiration)

<No>19-2

<Procedure> Move MNG1" from Link2(MNG1") to Link1(MN1G')  
(Move to next link before BCE expiration)

\*Do <No>19-1 and <No>19-2 at the same time as far as possible.

<No>20 Move from same link to another same link

<No>20-1

<Procedure> Move MNG0' from Link1(MNG0') to Link2(MN0G")  
(Move to next link before BCE expiration)

<No>20-2

<Procedure> Move MNG1' from Link1(MNG1') to Link2(MN1G")  
(Move to next link before BCE expiration)

\*Do <No>20-1 and <No>20-2 at the same time as far as possible.

<No>20-3

<Procedure> Stop ping

<No>21 Boot up both Groups on same Link

<No>21-1

<Procedure> Boot up MNG0 on Link1(MNG0').

<No>21-2

<Procedure> Boot up MNG1 on Link1(MNG1').

<No>21-3

<Procedure> Repeat ping MNG0'->MNG1' until <No>25-3.  
The pair of ping is described in Table Case-E.

<No>22 Move from same link to diffent Links

<No>22-1

<Procedure> Move MNG0' from Link1(MNG0') to Link2(MN0G")  
(Move to next link before BCE expiration)

<No>22-2

<Procedure> Move MNG1' from Link1(MNG1') to Link3(MN1G""")  
(Move to next link before BCE expiration)

\*Do <No>22-1 and <No>22-2 at the same time as far as possible.

<No>23 Move from different links to different Links

<No>23-1

<Procedure> Move MNG0" from Link2(MNG0") to Link3(MN0G")  
(Move to next link before BCE expiration)

<No>23-2

<Procedure> Move MNG1"" from Link3(MNG1"") to Link2(MN1G")  
(Move to next link before BCE expiration)

\*Do <No>23-1 and <No>23-2 at the same time as far as possible.

<No>24 Move from different links to same link

<No>24-1

<Procedure> Move MNG0"" from Link3(MNG0"") to Link1(MN0G')  
(Move to next link before BCE expiration)

<No>24-2

<Procedure> Move MNG1" from Link2(MNG1") to Link1(MN1G')  
(Move to next link before BCE expiration)

\*Do <No>24-1 and <No>24-2 at the same time as far as possible.

<No>25 Move from same link to another same link

<No>25-1

<Procedure> Move MNG0' from Link1(MNG0') to Link2(MN0G")  
(Move to next link before BCE expiration)

<No>25-2

<Procedure> Move MNG1' from Link1(MNG1') to Link2(MN1G")  
(Move to next link before BCE expiration)

\*Do <No>25-1 and <No>25-2 at the same time as far as possible.

<No>25-3

<Procedure> Stop ping

<No>26     Boot up both Groups on same Link

<No>26-1

<Procedure> Boot up MNG0 on Link1(MNG0').

<No>26-2

<Procedure> Boot up MNG1 on Link1(MNG1').

<No>26-3

<Procedure> Repeat ping MNG0'->MNG1' until <No>30-3.

          The pair of ping is described in Table Case-F.

<No>27     Move from same link to different Links

<No>27-1

<Procedure> Move MNG0' from Link1(MNG0') to Link2(MN0G")

          (Move to next link before BCE expiration)

<No>27-2

<Procedure> Move MNG1' from Link1(MNG1') to Link3(MN1G''')

          (Move to next link before BCE expiration)

\*Do <No>27-1 and <No>27-2 at the same time as far as possible.

<No>28     Move from different links to different Links

<No>28-1

<Procedure> Move MNG0" from Link2(MNG0") to Link3(MN0G''')

          (Move to next link before BCE expiration)

<No>28-2

<Procedure> Move MNG1''' from Link3(MNG1''') to Link2(MN1G'')  
(Move to next link before BCE expiration)

\*Do <No>28-1 and <No>28-2 at the same time as far as possible.

<No>29 Move from different links to same link

<No>29-1

<Procedure> Move MNG0''' from Link3(MNG0''') to Link1(MN0G')  
(Move to next link before BCE expiration)

<No>29-2

<Procedure> Move MNG1'' from Link2(MNG1'') to Link1(MN1G')  
(Move to next link before BCE expiration)

\*Do <No>29-1 and <No>29-2 at the same time as far as possible.

<No>30 Move from same link to another same link

<No>30-1

<Procedure> Move MNG0' from Link1(MNG0') to Link2(MN0G'')  
(Move to next link before BCE expiration)

<No>30-2

<Procedure> Move MNG1' from Link1(MNG1') to Link2(MN1G'')  
(Move to next link before BCE expiration)

\*Do <No>30-1 and <No>30-2 at the same time as far as possible.

<No>30-3

<Procedure> Stop ping